

※Thank you for selecting the Tracer BP series MPPT solar charge controller. Please read this manual carefully before using the product and pay attention to the safety information.

**Tracer BP series**

**--- MPPT Solar Charge Controller**

**1. Safety Information**

- Read all of the instructions in the manual before installation.
- DONOT disassemble or attempt to repair the controller.
- Install external fuse or breaker as required.
- Do disconnect the solar module and fuse/ breakers near to battery before installing or moving the controller.
- Power connections must remain tight to avoid excessive heating from a loose connection.
- Only charge batteries that comply with the parameters of controller.
- Battery connection may be wired to one battery or a bank of batteries.
- Risk of electric shock, the PV and load can produce high voltages when the controller is working.

**2. Overview**

The Tracer BP series solar charge controller adopt to the advanced Maximum Power Point Tracking charging methods, it enables the system charging and discharging management to obtain the most radical optimization. Increase the system flexibility, yet lower down the system cost. The controller support a variety of battery, for example sealed, gel, flooded and lithium battery. User can view and modify the working status and parameters. It can be widely used on solar home system, traffic signal, solar street light, solar garden lamp, etc. The features are listed below:

- Adopt high quality components of ST,IR and Infineon, make sure product using lifespan
- Wide working environment temperature
- Apply to lead-acid battery and lithium battery
- Lithium battery self-activating and low temperature protection function
- Maximum conversion efficiency of 98%
- Advanced Maximum Power Point Tracking (MPPT) technology, with tracking efficiency no less than 99%
- Ultra-fast tracking speed and guaranteed tracking efficiency
- Accurately recognizing and tracking of multiple power points
- PV power limitation function
- Monitoring and setting parameter via Mobile APP, PC Monitor setting software with RS485 communication interface.
- Use of standard Modbus communication protocol for RS485 bus connections, communication protocol compatibility much better
- Connecting the IOT(Internet of Things) module and Cloud Server monitoring software to realize remote monitoring of the multi-machine system
- The RS485 connector can provide power supply
- Aluminum housing for better cooling
- Real-time energy statistics function
- IP67 waterproof degree

**3. Product Features**

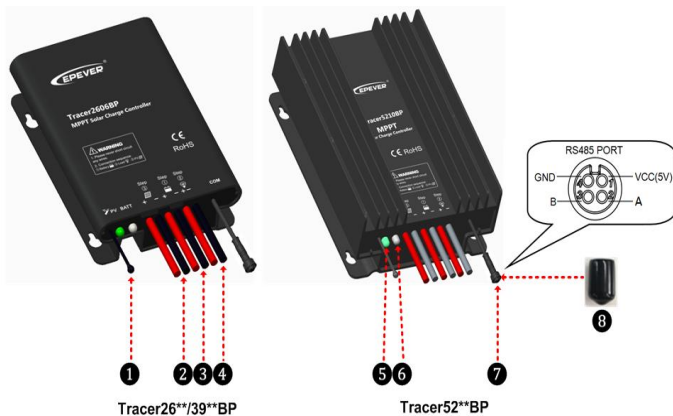

①	Temperature Sensor <sup>(1)</sup>	⑤	Charging Status LED indicator
②	PV Positive and Negative Wires	⑥	Battery Status LED indicator
③	Battery Positive and Negative Wires	⑦	RS485 waterproof port <sup>(2)</sup>
④	Load Positive and Negative Wires	⑧	Waterproof cap(Included)

(1)The temperature sensor short-circuited or damaged, the controller will be charging or discharging at the default temperature 25 °C.

(2)The port can provide the DC power supply of 5VDC/150mA and have the short circuit function.

NOTE: When the RS485 communication port is not working, the waterproof cap must be installed to prevent water getting in.

**4. Wiring**

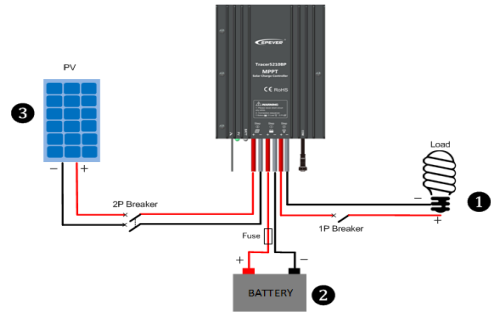

**• Connection Order**

- 1) Connect components to the charge controller in the sequence as shown above and pay much attention to the "+" and "-". Please don't insert the fuse or turn on the breaker during the installation. When disconnecting the system, the order will be reserved.
- 2) After power on the controller, check the battery LED indicator on the controller, it will be green. If it's not green, please refer to chapter 10.
- 3) Connect a fuse in series through battery positive (+) in the circuit and the battery circuit fuse must be 1.25 to 2 times to the rated current. The installed distance is within 150mm.

**• Load self-test function**

The load is ON when the controller power on 10s. After 10s it will restore to set working mode.

**5. LED Indicators**

Indicator	Color	Status	Instruction
PV	Green	On Solid	PV connection normal but low voltage(irradiance) from PV, no charging
	Green	OFF	No PV voltage(night time) or PV connection problem
	Green	Slowly Flashing(1Hz)	In charging
	Green	Fast Flashing(4Hz)	PV Over voltage
BATT	Green	On Solid	Normal
	Green	Slowly Flashing(1Hz)	Full
	Green	Fast Flashing(4Hz)	Over voltage
	Orange	On Solid	Under voltage
	Red	On Solid	Over discharged
	Red	Fast Flashing(4Hz)	Battery Overheating Low temperature
Charging(green) and battery indicator(orange)flashing simultaneously			System voltage error※

※When the battery type is Lithium Battery, the controller do not recognize the system voltage automatically.

**6. Load Working Mode**

- 1) Manual Mode(Default ON)
- 2) Light ON/OFF

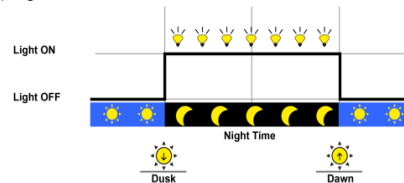

- 3) Light ON+ Timer

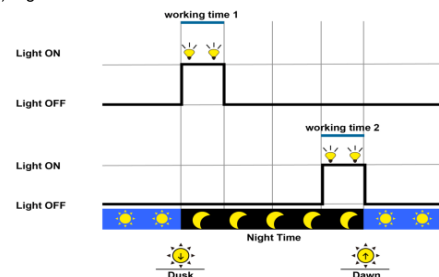

- 4) Real-time Control
- Control the load ON/OFF time through setting real-time clock.



NOTE: In the mode of Light ON/OFF and Light ON/Timer, the Load is turned on after 10Min. delay.

**7. Accessories(optional) and Software**

- 1) PC Software  
www.epever.com —Solar Station Monitor
- 2) APP Software
  - Android phone  
www.epever.com —ChargeController(Li)
  - IPhone  
APP Store —EPEVER —EP-01

※MT50 does not support the relevant parameters of lithium battery.  
 ※Specific instructions refer to the list of accessories and software.

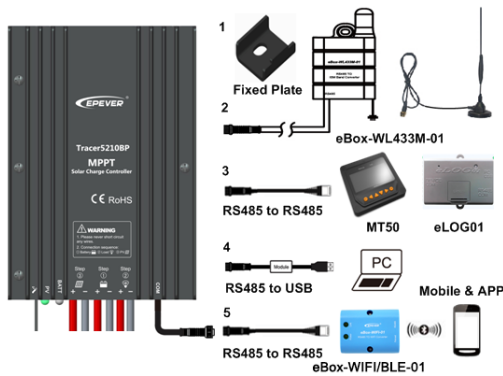

### 8. Protection

- PV Over Current**  
The controller will limit battery charging current to the Maximum Battery Current rating. Therefore an over-sized solar array will not operate at peak power.
- PV Short Circuit**  
When PV short circuit is powered on or PV input is short circuit on low-power, the controller will stop charging. Clear it to resume normal operation.
- WARNING: The controller may be damaged, when PV input is short circuit on high-power.**
- PV Reverse Polarity**  
Fully protection against PV reverse polarity, correct the wire connection to resume normal operation.
- WARNING: Controller will be damaged when the PV array straight polarity and the actual operation power of the PV array is 1.5 times greater than the rated charge power!**
- Battery Reverse Polarity**  
Fully protection against battery reverse polarity, correct the wire connection to resume normal operation.
- Battery Over Voltage**  
When the battery voltage reaches to the set point of Over Voltage Disconnect Voltage, the controller will stop charging the battery to protect the battery from being over charged to break down.
- Battery Over Discharge**  
When the battery voltage reaches to the set point of Low Voltage Disconnect Voltage, the controller will stop discharging the battery to protect the battery from being over discharged to break down.
- Battery Overheating**  
The controller detects the environment temperature through the external temperature sensor. If the environment temperature exceeds 65 °C, the controller will automatically start the overheating protection to stop working, and recover below 55 °C.
- Lithium battery Low Temperature**  
The temperature sensor is less than the low temperature value, Lithium battery stop charging/discharging. It is higher than the low temperature value, Lithium battery start charging/discharging.
- Load Overload**  
If the load current exceeds the maximum load current rating 1.05 times, the controller will disconnect the load. Overloading must be cleared up through reducing the load and restarting controller.
- Load Short Circuit**  
Load will be switched off when load short circuit (≥4 times rated current) happens.

Controller will automatically attempt to reconnect load for 5 times. If short circuit protection still exist after controller's 5 times attempts, user have to clear short circuit ,then restart the controller or wait for one night-day cycle (night time>3 hours).

- Temperature sensor break down**  
If the temperature sensor short-circuited or damaged, the controller will be charging or discharging at the default temperature 25 °C to prevent the battery damaged from overcharging or over discharged.
- High Voltage Transients**  
The controller is protected against small high voltage transients. In lightning prone areas, additional external suppression is recommended.

### 10. Troubleshooting

Faults	Possible reasons	Troubleshooting
LED Charging indicator turn off during daytime when sunshine falls on PV modules properly	PV array disconnection	Confirm that PV and battery wire connections are correct and tight
No LED indicator	Battery voltage maybe less than 8.5V	Measure battery voltage with the multi-meter. Min.8.5V can start up the controller
Battery LED indicator green fast Flashing	Battery over voltage	Check if battery voltage is higher than OVD, and disconnect the PV
Battery LED indicator red	Battery over discharged	When the battery voltage is restored to or above LVR point (low voltage reconnect voltage), the load will recover
Battery LED indicator red flashing	Battery Overheating	The controller will automatically turn the system off. But while the temperature decline to be below 50 °C, the controller will resume.
Load is not output	Load Overload <sup>①</sup>	①Please reduce the number of electric equipments. ②Restart the controller. ③wait for one night-day cycle (night time>3 hours).
	Load Short Circuit <sup>①</sup>	①Check carefully loads connection, clear the fault. ②Restart the controller. ③wait for one night-day cycle (night time>3 hours).

①When it is overload or short circuit, the load have 5 times auto-recovery output function, which each times delay respectively 5s, 10s, 15s, 20s, 25s.

### 11. Disclaimer

- This warranty does not apply under the following conditions:
- Damage from improper use or use in an unsuitable environment.
  - PV or load current, voltage or power exceeding the rated value of controller.
  - The controller is working temperature exceed the limit working environment temperature.
  - User disassembly or attempted repair the controller without permission.
  - The controller is damaged due to natural elements such as lightning.
  - The controller is damaged during transportation and shipment.

### 9. Technical Specifications

Item	Model	Tracer2606BP	Tracer3906BP	Tracer5206BP	Tracer2610BP	Tracer3910BP	Tracer5210BP	Tracer7810BP
Nominal system voltage		12/24VDC Auto( Lithium battery do not automatic identification system voltage)						
Battery input voltage range		8.5~32VDC						
Rated charge/discharge current		10A	15A	20A	10A	15A	20A	30A
Rated charge power		130W/12V;260W/24V	200W/12V;400W/24V	260W/12V;520W/24V	130W/12V;260W/24V	200W/12V;400W/24V	260W/12V;520W/24V	390W/12V;780W/24V
Max. PV open circuit voltage		60V( at minimum operating environment temperature ) 46V( at 25 °C environment temperature )			100V( at minimum operating environment temperature ) 92V( at 25 °C environment temperature )			
MPP Voltage range		( Battery voltage+2V)~36V			( Battery voltage+2V)~72V			
Battery Type		Lead-acid battery: Sealed(Default) / Gel / Flooded/User; Lithium battery:LiFePO4/ Li-NiCoMn/User						
Lead-acid	Equalize Charging Voltage	Sealed :14.6V/Gel: No / Flooded:14.8V/User:9-17V (X2/24V)						
	Boost Charging Voltage	Sealed :14.4V/Gel: 14.2V/Flooded:14.6V/User:9-17V (X2/24V)						
	Float Charging Voltage	Sealed/Gel/Flooded:13.8V/User:9-17V (X2/24V)						
	Low Voltage Reconnect Voltage	Sealed/Gel/Flooded:12.6V/User:9-17V (X2/24V)						
	Low Voltage Disconnect Voltage	Sealed/Gel/Flooded:11.1V/User:9-17V (X2/24V)						
Lithium	Boost Charging Voltage	LiFePO4:14.5V/ Li-NiCoMn:12.5V / User:9-17V (X2/24V)						
	Low Voltage Reconnect Voltage	LiFePO4:12.8V / Li-NiCoMn:10.5V / User:9-17V (X2/24V)						
	Low Voltage Disconnect Voltage	LiFePO4:11.1V / Li-NiCoMn:9.3V / User:9-17V (X2/24V)						
Self-consumption	≤13mA/12V;≤11.5mA/24V							
Temperature compensation coefficient	-3mV/°C/2V( Lithium battery don't have temperature compensation coefficient)							
Communication	RS485							
Working environment Tem.	-40°C ~ +60°C							
Enclosure	IP67							
Overall dimension	124x89x30mm	150x93.5x32.7mm	153x105x52.1mm	124x89x30mm	150x93.5x32.7mm	153x105x52.1mm	153.3x105x52.1mm	
Mounting hole size	Φ3.5mm							
Mounting dimension	88x76mm	120x83mm	120x94mm	88x76mm	120x83mm	120x94mm		
Power cable	14AWG(2.5mm <sup>2</sup> )		12AWG(4mm <sup>2</sup> )		14AWG(2.5mm <sup>2</sup> )		12AWG(4mm <sup>2</sup> ) 10AWG(6mm <sup>2</sup> )	
Net weight	0.54kg	0.74kg	1.20kg	0.54kg	0.74kg	1.20kg	1.26kg	

Any changes without prior notice! Version number: V2.2